



MAX FLOW SIZES FROM
500 TO 1500 GPM
(2000 TO 5600 LPM)

MAX LIQUID PRESSURE 300 PSIG (20.69 BAR) XHF SERIES

UNIVERSAL® Flow Meters

An Extra-Large Vane
Style For Liquids



XHF meter
with R Box



CSA Certified NRTL/C



CE Marked (as noted)

NIST Traceable Calibration
Certificate Available

DESCRIPTION

These variable-area flow meters have a spring-loaded swinging vane. Mounting is in-line and in any position. Straight pipe runs before or after are not required on the 4-inch meter. The meters require 2 pipe diameters straight run before and after the meter. The all-mechanical sensing system directly drives the pointer and remote signaling devices. They handle shocks or flow surges beyond their rated capacities.

The swinging vane can be manually operated with a factory supplied wrench to verify or adjust switch points, or to free the vane should it become lodged by debris in the fluid.

CALIBRATION

All flow meters are individually calibrated on fluids suitable to maintain the stated accuracy for viscosities up to 3000 SSU (650 Centipoise). We also compensate for specific gravity. For NIST Traceability please consult factory.

CONSTRUCTION MATERIALS

The meter body, moving parts, and seals are offered in a variety of materials to suit a wide range of applications: water, synthetic and petroleum based oils, paint, some corrosives, solvents, and air and gases. The flowmeter body is made up of the "center section" which is where the moving parts are. Sometimes it is cost effective to match this to other materials for the in and out-flow sections of the meter body and flanges. See selections in the "How to Order" section. Please consult the factory for compatibility of materials with your application.

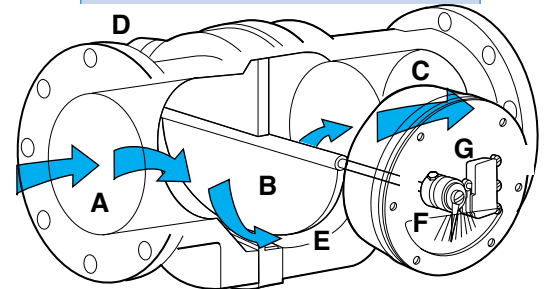

Fluid enters at **A**, passes around the semi-circular vane **B**, exits at outlet **C**. The vane resists the flow because of the spring **D**. The further the vane is pushed the larger the passageway **E** becomes. This minimizes pressure drop. The vane shaft turns to operate the pointer **F** and remote signal devices such as the switch **G**.

HOW TO ORDER Select appropriate symbols and build a model code number, as in example shown:

EXAMPLE: XHF -

Q I B 800GM - 32V1.0 -

SERIES BY PRESSURE RATING

Extra high vane style = **XHF**

Material of meter body, center section and flanges

In and outflow body portions	Center section	Flange		
Aluminum	Aluminum	Aluminum	Oil	D
Carbon steel	Carbon steel	Carbon steel	Oil	M
Carbon steel (nickel plated)	Carbon steel (nickel plated)	Carbon steel (nickel plated)	Water	J
Aluminum (hard coat)	Aluminum (hard coat)	Aluminum (hard coat)	Oil with corrosive environment	E
Stainless steel (316)	Stainless steel (316)	Stainless steel (316)	Chemicals, corrosives, water	I
Aluminum	Brass	Aluminum	Water	Q
Carbon steel	Stainless steel (316)	Carbon steel	Water, oil	X

INTERNAL MOVING PARTS

Stainless steel (316 series) = **I**

SEAL MATERIAL

Buna N	Water, oil	B
EPR	Water, hot water, some caustics	E
Viton®	Acids, some caustics	F
Kalrez™ (dynamic) and Teflon (static)	Corrosives, solvents	T
Kalrez (dynamic) and Buna N (static)	Specialty	A
Kalrez (dynamic) and EPR (static)	Specialty	H
Kalrez (dynamic) and Viton (static)	Specialty	K

MAX FLOW RATE LIQUIDS

GPM	500, 600, 800 , 1000, 1500	=	GM
LPM	2000, 2500, 3000, 3500, 5600	=	LM
CMH	120, 140, 180, 220, 340	=	GMH

*Requires special option DS.

PORT CONNECTION

150-lb ANSI Weld-Neck Flanges				
Size	Max. Flow		Symbol	
Inches	MM	(GPM)	(LPM)	
4	101.6	600	2271	32W
6	152.4	1000	3785	48W
8	203.2	1500	5677	64W

FLUID CHARACTERISTICS

Viscosity number followed by a 'V' (for SSU), 'C' (for centipoise), or 'CS' (for centistokes) followed by the specific gravity. Example: **32V1.0** would indicate a fluid with a viscosity of 32 SSU with a specific gravity of 1. For dual viscosities (where there is a start up viscosity or where there may be a range) put in both values with a slash. Example: **32Ø/15ØV.9**.

Consult factory for compatibility of construction materials with the fluid involved.

Viton® and Kalrez™ are registered trademarks for DuPont Performance Elastomers.

RX1 W L - ST - 50D

SERVICE	
Weatherproof (Type 4)	= W
Weatherproof, corrosion proof (Type 4X)	= X

FLOW DIRECTION	
Left to right	= R
Right to left	= L
Up	= U
Down	= D

SPECIAL OPTIONS	
High-temp- 400°F for A & R Box, 300°F for transmitter options	= HT
Stainless steel ID tag for customer supplied information	= ST
Pin connector (See explanation for special options.)	= PC
Tempered glass window	= TG

SWITCH SETTING	
No symbol	= Lowest possible setting (usually 10% of maximum flow)
Desired set point is assumed to be in flow units already selected (GPM). Give flow rate followed by a "D" for flow going down (flow failure) or a "U" for flow going up.	
Example, 50D indicates a setting of 50 GPM in declining flow.	

CONTROL BOX & READOUT			
Basic Features	Additional Options	High resolution pointer and inscribed scale	Separate junction boxes (with terminal strips) for switch & transmitter
↓	↓	"R" Box	"T" Box
		Materials of Construction	
		Aluminum	Aluminum
These options all include inscribed scale and pointer plus one of the standard (non hazardous location) switches selected to the right.	No switch	R0	
	One SPDT (3 wire), CE	R1	
	One high vibration SPDT (3 wire), CE	R1B	
	Two SPDT (3 wire), CE	R2	
	Two high vibration SPDT (3 wire), CE	R2B	
	One SPDT (4 wire)	R3	
	Two SPDT (4 wire)	R4	
	One SPDT (3 wire) high temperature	R61	
	Two SPDT (3 wire) high temperature	R62	
	One SPDT (3 wire) gold contact	R71	
Two SPDT (3 wire) gold contact	R72		
These options all contain inscribed scale with pointer plus hazardous location switches selected to the right. Note that the box is not rated, only the switches.	One SPDT hazardous location (all classes, groups and divisions)	R7	
	One DPDT hazardous location (all classes, groups and divisions)	R17	
	Two SPDT hazardous location (all classes, groups and divisions)	R18	
	Two DPDT hazardous location (all classes, groups and divisions)	R19	
	One SPST hazardous location proximity (all classes, groups and divisions)	R30	
	Two SPST hazardous location proximity (all classes, groups and divisions)	R31	
These options all contain a 4-20 mA transmitter and one of the selections to the right.	No switches (Intrinsically safe with barrier)	RX0	TX0
	One SPDT (3 wire), CE	RX1	TX1
	Two SPDT (3 wire), CE	RX2	TX2
	One SPDT (4 wire)	RX3	TX3
	Two SPDT (4 wire)	RX4	TX4
	One SPDT (3 wire) high temperature	RX61	TX61
These options all include a 4-20 mA transmitter with a digital LCD display plus one of the selections to the right.	No switches		TXL0
	One SPDT (3 wire), CE		TXL1
	One SPDT (4 wire)		TXL3
	One SPDT (3 wire) high temperature		TXL61

CONTROL BOX SELECTION GUIDE

STANDARD OFFERING: Control Box "R"



"R" box is selected for greater resolution (more increments on the inscribed scale).

It holds switches (general purpose and hazardous location all classes groups and divisions) and 4-20mA transmitter. Switch (standard service) and transmitter are offered in this control box together when signal redundancy is desired.

You get this control box when you order any CONTROL BOX & READOUT starting with an "R" (see "How to Order" page). Examples: R1WR is a one switch, weatherproof box with flow from left to right.

This control box is made from epoxy coated aluminum.

SPECIAL OFFERING: Control Box "T"



"T" box is selected for availability of two isolated junction boxes with terminal strips. This means that no direct wiring to switches or transmitters is required.

Digital LCD display of flow is optional ("TTL").

It holds switches (general purpose) and 4-20mA transmitter. Switch (standard service) and transmitter are offered in this control box together when signal redundancy is desired. These are wired to separate junction boxes for signal isolation.

You get this control box when you order any CONTROL BOX & READOUT starting with a "T" (see "How to Order" page). Examples: TT1WR is a one switch with 4-20mA transmitter, weatherproof box with flow from left to right.

This control box is made from epoxy coated aluminum.

Outline drawing for all control box options

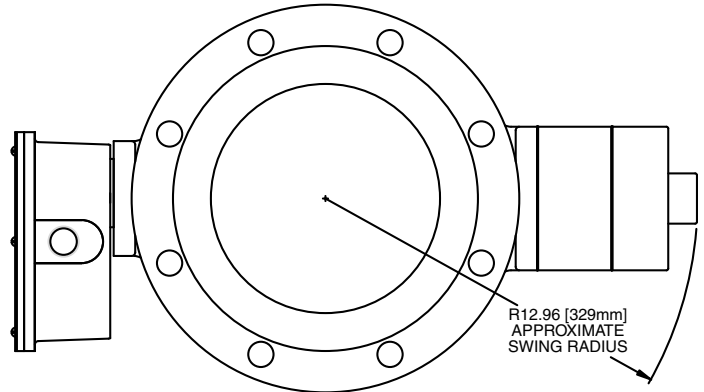
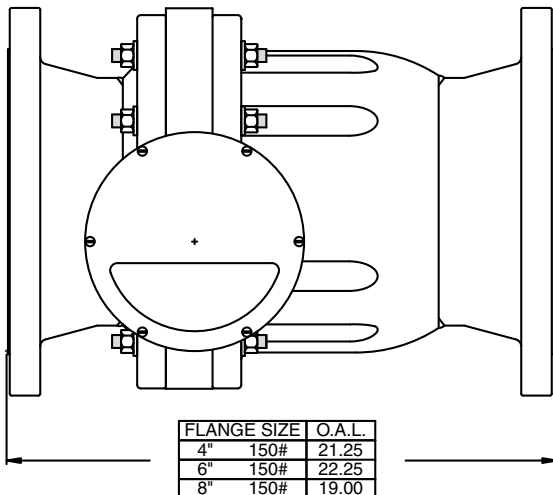

SPECIAL OPTIONS

High temperature: (option HT) requires seals of Viton®, EPR, Kalrez™ or Teflon (compatible with fluid). A thermal barrier (heat-resistant cloth) is added between the housing and the control box, which must be used with service option "W" (weather-proof) or "X" (corrosion resistant). A metal scale is provided.

Identification tag: (option ST) customer-supplied information is stamped on a stainless steel tag that is attached to the nameplate.

Multi-pin connector: Pin connectors (option PC) are available for rapid field installation. Meters are provided with the male half of either a micro or a mini pin connector. Check the chart below for the number of pins required for your control box selection and current type. Insert the number of pins in the code PC__ for a mini connector or PC__M for a micro connector. For example, a PC5 would be a 5 pin mini and PC5M would be a 5 pin Micro. (See table below for number of pins required for each option.)

Tempered-glass window: (option TG) replaces the standard window. A tempered-glass window is employed where airborne solvents or high-ambient temperatures are common.

Number of pins required for various combinations of current type, box type and switch option.

	AC switch options		1, 1B, 61, 71	1, 1B, 61, 71	3	3	53	
	DC switch options	0	1, 1B, 61, 71	3	2, 2B, 54, 62, 72		53	
Box	A		3	4	6	5	3	4
	R		3	4	6	5	3	4
	RX	3						
	TX	3	3	4			3	4
	TXL	3	3	4			3	4

*This box allows micro pin connectors only. Eg. PC3M or PC5M.

ENGINEERING DATA

Maximum fluid temperature:
200°F (95°C)

Optional max. fluid temperature:
400°F (205°C)

Maximum ambient temperature:
150°F (65°C)
CSA listed only to 105°F (40°C)

Maximum operating pressure
(3:1 safety factor):
300 PSI (20.69 BAR)

Readout accuracy, full scale:
±2%

FLOW & PRESSURE DROP

Units with max flow of 800 GPM or less have a max pressure drop of 3.8 PSI. All others have maximum pressure drop of 5.5 PSI.



Universal Flow Monitors, Inc.

1755 E. Nine Mile Road ▪ P.O. Box 249 ▪ Hazel Park, MI 48030
Tel: 248-542-9635 ▪ Fax: 248-398-4274
www.flowmeters.com ▪ E-mail: ufm@flowmeters.com